

F FORESTS

AN ESSENTIAL PIECE IN
THE DECARBONISATION
PUZZLE

Forests: An essential piece in the decarbonisation puzzle

Modelling the forestry sector of India

Center for Study of Science, Technology and Policy
August 2023

Designed and Edited by CSTEP

Disclaimer

While every effort has been made for the correctness of data/information used in this report, neither the authors nor CSTEP accepts any legal liability for the accuracy or inferences of the material contained in this report and for any consequences arising from the use of this material.

© 2023 Center for Study of Science, Technology and Policy (CSTEP)

Any reproduction in full or part of this publication must mention the title and/or citation, which is provided below. Due credit must be provided regarding the copyright owners of this product.

Contributors: Aparna Sundaresan, Kaveri Ashok, Ramya Natarajan, and Sweta Bhushan

(The author list provided assumes no particular order as every individual contributed to the successful execution of the project.)

This report should be cited as follows: CSTEP. (2023). *Forests: An essential piece in the decarbonisation puzzle*. (CSTEP-RR-2023-9).

August 2023

Center for Study of Science, Technology and Policy

Bengaluru

18, 10th Cross, Mayura Street
Papanna Layout, Nagashettyhalli
RMV II Stage, Bengaluru 560094
Karnataka (India)

Noida

1st Floor, Tower-A
Smartworks Corporate Park
Sector 125, Noida 201303
Uttar Pradesh (India)

Tel.: +91 (80) 6690 2500

Email: cpe@cstep.in

Acknowledgements

We are grateful to our internal reviewers Dr Indu K Murthy and Tashina Madappa for their comments, insights, and encouragement. We thank our external reviewers Dr Prakash Lakhchaura, DDG (Training and Forest Inventory Division), Forest Survey of India; Dr Kiran Chand Thumaty, National Remote Sensing Centre; and Dr Manan Bhan, Ashoka Trust for Research in Ecology and Environment, for their valuable inputs and insights. Feedback from the reviewers has helped us strengthen our analyses and arguments. We would also like to thank our Communications and Policy Engagement team for the editorial and design support.



CO2

Executive Summary

India has announced its net-zero target for the year 2070, and many measures are being taken to decarbonise various sectors of the country. However, achieving net-zero targets is contingent on carbon capture and storage, given there are certain hard-to-abate sectors. In this light, forestry becomes an important sector as forests are natural carbon sinks that capture atmospheric carbon dioxide using their photosynthetic ability and store it over a long period of time as biomass.

Over the past two decades, India has seen growth in forest and tree cover despite developmental activities. India in its 2015 Nationally Determined Contributions (NDC) committed to creating an additional sink of 2.5 to 3 billion tonnes of carbon dioxide equivalent (CO₂-e) through the expansion of forest and tree cover by 2030. It is against this background that we at the Center for Study of Science, Technology and Policy (CSTEP) created a system dynamic model to understand the long-term carbon sequestration potential of the country and analyse the policy choices available to help achieve the NDC targets in the forest sector.

To demonstrate the ability of the model, we simulated five scenarios for achieving two specific targets: NDC-1 (creating an additional 2.5 billion tonnes of CO₂-e sink) and NDC-2 (creating an additional 3 billion tonnes of CO₂-e sink). For the five chosen scenarios—all meeting the NDC targets (provided in Table A)—we analysed the total CO₂-e sink, the annual carbon capture, and the percentage of forest and tree cover achieved for the years 2030 and 2070. The model-generated carbon stocks and sink capacity values (from 2011 to 2016) were validated using the National GHG inventory and the FSI technical report datasets. On an average the differences between the model-generated stock values and these public datasets were 0.51% and 0.98%, respectively.

Table A: The description of scenarios

Scenario	Description
NDC-1 Aff NDC-2 Aff	Increasing only afforestation activities
NDC-1 Def NDC-2 Def	Reducing only deforestation activities
NDC-1 Aff + Res NDC-2 Aff + Res	Increasing both afforestation and restoration activities
NDC-1 Def + Deg + Res NDC-2 Def + Deg + Res	Decreasing deforestation and degradation and increasing restoration activities
NDC-1 Aff + Def + Deg + Res NDC-2 Aff + Def + Deg + Res	Increasing afforestation and restoration activities and decreasing deforestation and degradation activities

Note: Aff – Afforestation, Def – Deforestation, Res – Restoration, and Deg – Degradation

In the business-as-usual (BAU) scenario, the afforestation, deforestation, degradation, and restoration activities are assumed to follow the average historical trend. The total CO₂-e sink achieved by 2030 in this scenario is 31.1 billion tonnes, which is 0.9 to 1.4 billion tonnes short of the NDC target.

In the aggressive afforestation scenario (NDC-1 Aff and NDC-2 Aff), the annual carbon capture and the percentage of forest and tree cover attained in 2030 and 2070 are the highest (up to 23% higher) compared to all other scenarios. However, the expansion of forest and tree cover in this scenario is highly contingent on the availability of land.

Under the second scenario of reduced deforestation (NDC-1 Def and NDC-2 Def), the annual carbon capture in 2070 is the lowest in comparison to the other scenarios. Moreover, developmental activities across the country can increase demand for land, requiring the diversion of forest land for non-forest purposes. Thus, a drastic reduction in deforestation activities, such as in this scenario, might not be feasible.

Increasing both afforestation and restoration activities to achieve NDC targets, as seen in the third scenario (NDC-1 Aff + Res and NDC-2 Aff + Res), requires a large area to be brought under forests via restoration activities. Although NDC targets can be achieved with such efforts, it is contingent on the viability of scrubland and open forests to be converted to higher density forest areas. This can risk ecologically important ecosystems supported by scrubland and open forests.

The fourth scenario looked at the reduction in both deforestation and degradation with an increase in restoration activities (NDC-1 Def + Deg + Res and NDC-2 Def + Deg + Res). Although the annual carbon capture is low, the NDC targets of total CO₂-e sink are achievable with a moderate reduction in deforestation, unlike the second scenario. This can reduce the competition for land among various sectors, with more forest land available for diverting towards non-forest purposes.

Finally, we looked at a combination of all interventions: NDC-1 Aff + Def + Deg + Res and NDC-2 Aff + Def + Deg + Res. Moderate levels of total CO₂-e sink and annual carbon capture are reached by 2070 in this scenario. Given that this scenario assumes the least effort across interventions and results in achieving the 2030 NDC targets, it is probably the most likely scenario for long-term forest management and expansion.

There are several policies in place that impact the forestry sector in India. The forestry model we have built can work as a decision support tool not only to evaluate policies in terms of carbon sinks and forest cover but also to understand where they may hit the limits and what the trade-offs could be. This modelling exercise was conducted to evaluate the possibilities of achieving NDC targets in the forestry sector. In the next phase, we plan to integrate the forestry model into CSTEP's Sustainable Alternative Futures for India (SAFARI) model, which will help analyse the land competition with the agriculture sector, renewable energy power plants, and urbanisation.

Contents

1. Introduction.....	13
2. Methodology.....	15
2.1. Area under forest cover	16
2.2. Area under tree cover.....	16
2.3. Carbon sequestered.....	17
3. Scenario building.....	19
3.1. Scenario description.....	19
4. Validation.....	21
5. Results and discussion.....	23
5.1. Aggressive afforestation scenario: NDC-1 Aff and NDC-2 Aff.....	25
5.2. Reduced deforestation scenario: NDC-1 Def and NDC-2 Def	25
5.3. Afforestation and restoration scenario: NDC-1 Aff + Res and NDC-2 Aff + Res.....	25
5.4. Reduced deforestation and degradation and increased restoration scenario: NDC-1 Def + Deg + Res and NDC-2 Def + Deg + Res	26
5.5. Afforestation and restoration and reduced deforestation and degradation scenario: NDC-1 Aff + Def + Deg + Res and NDC-2 Aff + Def + Deg + Res.....	26
6. Forest policies in India	27
7. Way forward.....	28
8. References.....	29

Figures

Figure 1: Schematic representing the carbon sequestration process in forests	14
Figure 2: Modelling logic for the forest sector	15

Tables

Table 1: Scenario assumptions to reach the NDC target of 2.5 billion tonnes of additional CO ₂ -e by 2030	20
Table 2: Scenario assumptions to reach the NDC target of 3 billion tonnes of additional CO ₂ -e by 2030	20
Table 3: Comparison between the National GHG inventory, the FSI technical report, and the Forestry model outputs on the total carbon stock in area under forest cover (in million tonnes carbon and in billion tonnes CO ₂ -e).....	22
Table 4: Effort required or result achieved from the most (green) to the least (red) for each intervention/variable across the scenarios	24

Abbreviations

NDC	Nationally Determined Contributions
CO ₂ -e	Carbon dioxide equivalent
BAU	Business as usual
Aff	Afforestation
Res	Restoration
Def	Deforestation
Deg	Degradation
SAFARI	Sustainable Alternative Futures for India
LT-LEDS	Long-term Low Emission Development Strategy
UNFCCC	United Nations Framework Convention on Climate Change
GDP	Gross Domestic Product
Mission LiFE	Mission Lifestyle for Environment
GPP	Gross Primary Productivity
NPP	Net Primary Productivity
FSI	Forest Survey of India
ISFR	Indian State Forest Report
LULUCF	Land use, Land-use change and Forest
VDF	Very dense forest
MDF	Moderately dense forest
OF	Open forest
CEC	Central Empowered Committee



1. Introduction

India is one of the fastest-growing economies and home to one sixth of the world's population. Although India is the third-largest emitter in the world, it has contributed to only 7% of the total world emissions as of 2021, and its per capita emission rate at 2.4 tCO₂-e is far below the global average (United Nations Environment Programme, 2022). India has set an ambitious target to achieve net-zero emissions by 2070. At COP27, India released its Long-term Low Emission Development Strategy (LT-LEDS), which provides a framework to achieve this target (Ministry of Environment, Forest and Climate Change, 2022). India has also reaffirmed its commitment to the United Nations Framework Convention on Climate Change (UNFCCC) and the Paris Agreement by updating its Nationally Determined Contribution (NDC) goals and targets, committing to reduce the emission intensity of gross domestic product (GDP) by 45% by 2030 compared to the 2005 levels (Press Information Bureau, 2022). India also launched Mission LiFE (Lifestyle for Environment), which aims to promote a healthy lifestyle with lower and more purposeful rates of resource consumption.

India's efforts in mitigating climate change are driven by not only climate policies but also development choices. While decarbonisation measures across various sectors of the economy are targeted to bring down emissions significantly, reaching net zero will be contingent on carbon capture and storage as there are some hard-to-abate sectors (Levin et al., 2020). Forests are an essential part of the global carbon cycle and play the dual role of carbon capture and storage, both of which contribute to carbon sequestration (Malhi, 2012). Carbon capture by forests refers to the process of absorbing atmospheric carbon dioxide and directing it towards biomass and soil. Additionally, forests also ensure that the carbon captured by trees and other vegetation remains stored for a long period of time. The stored carbon remains so until it is either decomposed or burnt and thus released back into the atmosphere.

The total carbon dioxide taken up by trees or fixed by photosynthesis is termed gross primary productivity (GPP). Almost 70% of the carbon in GPP is converted to usable energy for metabolic processes and thus released back into the atmosphere in the form of autotrophic respiration. The remaining 30% of the carbon in GPP, which is termed net primary productivity (NPP), is directed towards storage. Most of the carbon coming from NPP is stored mainly in trunks, branches, and roots of trees and is called woody productivity. When this carbon is stored for a long period of time, usually decades, it is termed standing biomass. The standing biomass of the forest also depends on the mortality rate of the trees in a forest, which is governed by both natural processes and management practices. The whole process of carbon capture and storage together is called carbon sequestration (see Figure 1).

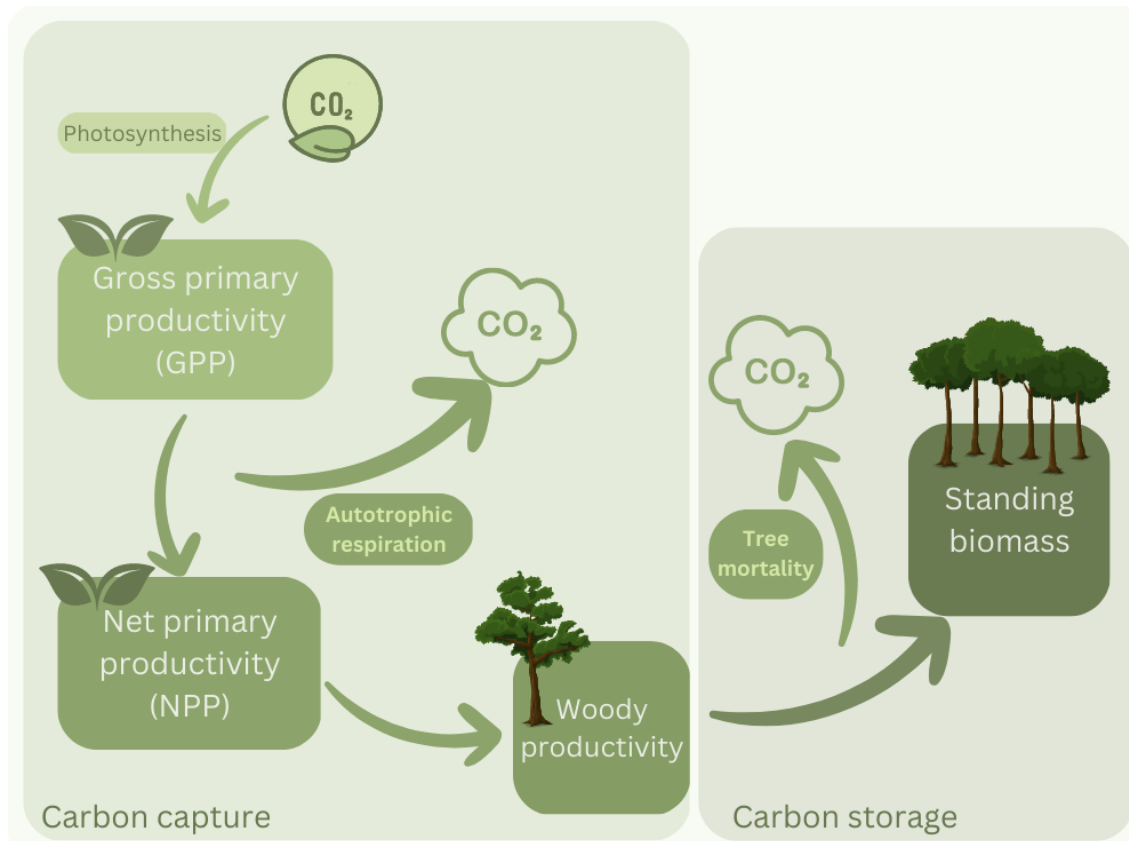

Figure 1: Schematic representing the carbon sequestration process in forests

India is one of the few countries where forest and tree cover has been increasing over the past two decades (Forest Survey of India, 2021) despite ongoing developmental activities. According to the Third Biennial Update Report submitted to the UNFCCC, the land use, land-use change and forest (LULUCF) sector has been a net sink of 307,820 Gg CO₂-e in 2016, and this sink has increased by 3.4% between 2014 and 2016 and 40% between 2000 and 2016 (Ministry of Environment, Forest and Climate Change, 2021b). The forest and tree cover alone holds 7,204 million tonnes of carbon stock (Forest Survey of India, 2013), and as per the 2015 NDC targets, India aims to create an additional sink of 2.5 to 3 billion tonnes of CO₂-e through the expansion of forest and tree cover by 2030 (Press Information Bureau, 2022).

The overall objective of this study was to develop a system dynamic simulation model for the forestry sector to help understand the carbon sequestration potential of the country. The study also explores how the NDC targets pertaining to the forestry sector can be met and if India can go beyond these targets.

2. Methodology

According to the Forest Survey of India (FSI), forest is defined as an area with more than or equal to 1 hectare of land with tree cover having more than 10% canopy density. These are further divided into different density classes:

- Very dense forests (VDF): The forests in this class have a canopy density greater than 70%.
- Moderately dense forests (MDF): The forests in this class have a canopy density of more than 40% but less than 70%.
- Open forests (OF): The forests in this class have a canopy density between 10% and 40%.

FSI also provides data on the tree cover of the country. As per its definition, any area less than 1 hectare with less than 10% canopy density is considered for tree cover estimates. These include areas outside forests such as parks, highways, roads, and railway tracks. Since the NDC targets mention the expansion of both forest and tree cover, we have included both these areas in our model for analysis. The base year for the forestry model is 2011, calibrating to the 2011 Census of India. Choosing this base year enabled us to establish the robustness of the model based on recommended validation processes such as structure and behaviour pattern reproduction tests (2011–2022) for system dynamics simulation models. For the base year, the stock values of forest and tree cover reported in the India State of Forest Report 2013 (Forest Survey of India, 2013) are considered.

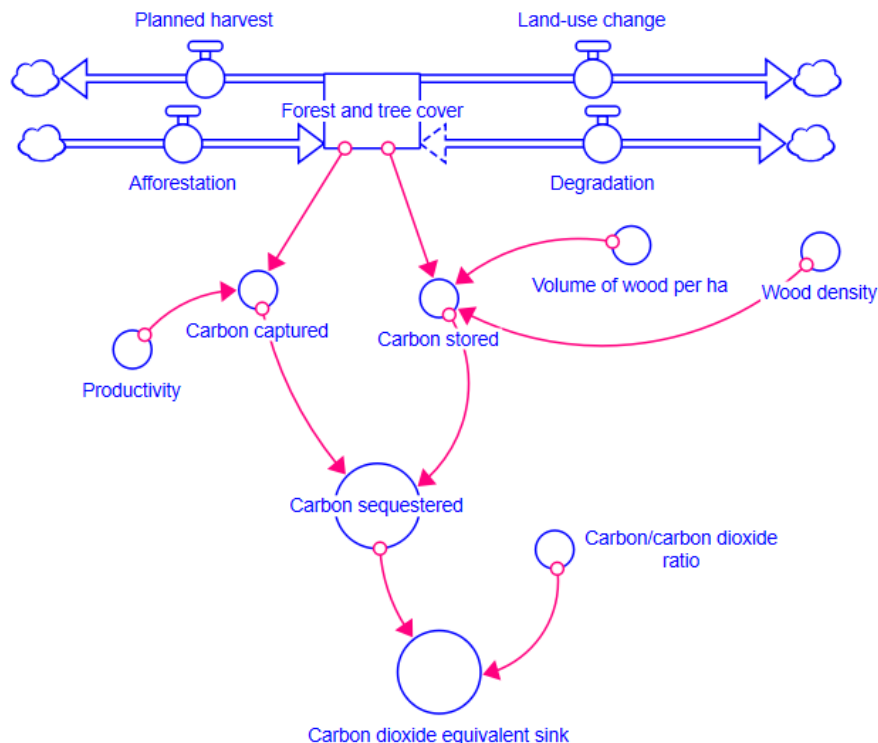

Figure 2: Modelling logic for the forest sector

Figure 2 shows the basic structure of the model. 'Forest and tree cover' is the main *stock* with 'Afforestation' being *inflow* and 'Planned harvest' and 'Land-use change' being *outflows*. A *biflow* of 'Degradation' that flows to and from the 'Forest and tree cover' stock is also accounted for. The annual 'Forest and tree cover' stock is used to calculate both the carbon captured and stored for each year, which is then used to calculate the total carbon dioxide equivalent (CO₂-e) sink. The details of each of the variables are presented in the following sections.

2.1. Area under forest cover

Historical data for areas under different density classes are provided by the biennial India State of Forest Report (ISFR) published by FSI. The formula for calculating the total forest and tree cover is

$$\text{Forest cover}_t = \text{Forest cover}_{t-1} + \text{Afforested area}_t - \text{Degraded area}_t + \text{Restored area}_t - \text{Deforested area}_t,$$

where t is time and the other parameters are obtained using the change matrix provided in the ISFR pertaining to different periods.

- **Afforested areas:** Any non-forest land that is converted to forest land is considered an afforested area. Afforested areas are considered young forests until 20 years, beyond which they are considered old-growth forests. This creates two age classes—less than 20 years and greater than 20 years.
- **Degraded and restored areas:** The transitioning of forest land to scrubland or transitioning from high-density forest to low-density forest classes, such as the conversion of VDF to either MDF or OF, is considered degradation. Conversely, the conversion of scrubland to forest land or the conversion of low-density forest land to high-density forest land is assumed to be a result of restoration activities, and therein the area converted is considered a restored area.
- **Planned harvest:** Any commodity-driven clearing or temporary loss of forest land/plantation is considered a planned harvest. These include rotational tree felling and/or shifting cultivation.
- **Land-use change:** The clearing of forest land because of a development-led activity, encroachment activity, or mining activity is considered land-use change.

In the model, the forest cover area for each of the density classes is calculated separately. Since degradation and restoration involve the transition of forests between density classes, these stocks interact with each other.

2.2. Area under tree cover

The area under tree cover is given separately by the ISFR reports, and this is considered as it is in the model. It is assumed in the model that no deforestation or degradation takes place in the area classified as tree cover. The historical trend in the increase in tree cover is considered the area afforested in the land classified as tree cover.

2.3. Carbon sequestered

Carbon sequestration has two aspects: carbon captured and carbon stored. It is the sum of the two parameters.

Carbon capture—the ability of the forest to absorb carbon dioxide from the atmosphere—is calculated separately for each forest density and each age class and is given by

$$\text{Area under forest cover} \times \text{Productivity} \times \text{Average canopy density.}$$

Productivity is the photosynthetic ability of the forest and an empirically derived value. We calculated an average productivity value for each age class at the national level based on a study conducted by Houghton and Hackler (2001). The study classifies forests as moist, seasonal, and open. We matched this classification with the different forest types found in the country such as tropical moist evergreen forest, tropical dry deciduous forest, and tropical dry thorn forest. We then assigned productivity values to this combined classification. The average of these assigned values was used as the productivity value in the model.

Average canopy density is used as a weightage to differentiate between the carbon capture ability of each density class and is calculated as an average of the minimum and maximum density seen in that class. For example, for the VDF class, the minimum canopy density seen is 70% and the maximum is 100%. Thus, the average canopy density for the VDF density class is 85%, which is converted as a weight to 0.85. The values used for the average canopy density in the model are 0.85 for VDF, 0.55 for MDF, and 0.25 for OF.

Carbon storage—the carbon stored in the wood, roots, and leaves over time—is calculated as follows:

$$\text{Area under forest cover} \times \text{Average volume of wood per hectare} \\ \times \text{Average wood density.}$$

The average volume of wood per hectare and the average wood density in the above formula were calculated separately as follows:

$$\text{Average volume of wood per hectare} = \frac{\sum \frac{\text{Growing stock volume}_t}{\text{Area under forest cover}_t}}{\text{Number of years}} \text{ and}$$

$$\text{Average wood density} = \frac{\sum \frac{\text{Carbon stock}_t}{\text{Growing stock volume}_t}}{\text{Number of years}},$$

where t is the year for which the area is reported in the ISFR report. For both variables, data from 2013 to 2021 FSI biennial ISFR reports were considered, and therefore, the number of years used in the formulae is five.

The final formula adopted for calculating the total CO₂-e sink for the country is

$$\text{Total carbon sequestered} \times \text{CO}_2 \text{ to C mass ratio,}$$

where the CO₂ to C mass ratio is 44/12



3. Scenario building

The NDC targets for the forest sector were set in 2015. At this time, the total CO₂-e sink including both forest and tree cover reported for India was 29.5 billion tonnes. Achieving 2.5 to 3 billion tonnes of additional sink capacity compared to that reported for 2013 in ISFR 2015 will increase the total CO₂-e sink capacity to 32 to 32.5 billion tonnes by 2030.

According to the business-as-usual (BAU) scenario in our model, assuming current average afforestation, deforestation, restoration, and degradation rates, the total CO₂-e sink that can be realised by 2030 in India is 31.1 billion tonnes, falling short by 0.9 to 1.4 billion tonnes.

The interventions considered for achieving this goal are as follows:

1. Increase afforestation.
2. Increase restoration activities.
3. Reduce degradation through conservation activities.
4. Reduce deforestation: Reduction in land-use change and/or commodity-driven felling of trees. In the current analysis, the distinction for interventions addressing land-use change related to deforestation and harvest has not been made.

It is assumed that all interventions would be carried out up till the year 2025 in a phased manner to achieve the NDC targets by 2030.

3.1. Scenario description

A description of the scenarios to achieve 2.5 and 3 billion tonnes of additional CO₂-e by 2030, considering the reference year as 2015, and the assumptions on interventions are presented in Table 1 and Table 2.

Under NDC-1 (creating additional 2.5 billion tonnes of CO₂-e) and NDC-2 (creating additional 3 billion tonnes of CO₂-e) targets, five scenarios with different interventions (individual and/or combined) are considered.

Under each scenario, we estimated the total CO₂-e sink, the annual carbon capture, and the percentage of forest and tree cover for 2030 and 2070. No land constraints were assumed under any of the scenarios.

Table 1: Scenario assumptions to reach the NDC target of 2.5 billion tonnes of additional CO₂-e by 2030

Scenario	Percentage of increase or decrease in addition to the BAU				
	Afforestation		Deforestation	Restoration	Degradation
	Forest cover	Tree cover			
NDC-1 Aff	+40	+60	0	0	0
NDC-1 Def	0	0	-60	0	0
NDC-1 Aff+Res	+20	+50	0	+90	0
NDC-1 Def+Deg+Res	0	0	35	50	-50
NDC-1 Aff+Def+Deg+Res	+15	+50	-10	+50	-50

Note: BAU – Business as usual, the + sign indicates a % increase in afforestation and restoration, and the – sign indicates a % decrease in deforestation and degradation.

Table 2: Scenario assumptions to reach the NDC target of 3 billion tonnes of additional CO₂-e by 2030

Scenario	Percentage of increase or decrease in addition to the BAU				
	Afforestation		Deforestation	Restoration	Degradation
	Forest cover	Tree cover			
NDC-2 Aff	+65	+100	0	0	0
NDC-2 Def	0	0	-90	0	0
NDC-2 Aff+Res	+40	+85	0	+100	0
NDC-2 Def+Deg+Res	0	0	-55	+80	-80
NDC-2 Aff+Def+Deg+Res	+30	+60	-15	+70	-70

Note: BAU – Business as usual, the + sign indicates a % increase in afforestation and restoration, and the – sign indicates a % decrease in deforestation and degradation.

4. Validation

To validate the model, we compared the carbon stock (million tonnes of carbon) and the total CO₂-e sink (in billion tonnes) values for a given area under forest cover as generated by the model with the values reported in the FSI technical report (Forest Survey of India, 2019), and the National GHG inventory (Ministry of Environment, Forest and Climate Change, 2021b). This helped validate the model outputs derived independent of the numbers from the National GHG inventory and the FSI technical report. The maximum difference in the stocks and sink capacity between the model-generated numbers and the aforementioned public datasets was observed in 2011 (1.3% compared to the National GHG Inventory and 2.4% compared to the FSI technical report). This difference is mainly because of the averages considered at the national level for various parameters in the calculation of carbon stocks, such as the average volume of wood per hectare, the average wood density, and the average productivity of the forests. The detailed results of the validation exercise are provided in Table 3.



Table 3: Comparison between the National GHG inventory, the FSI technical report, and the Forestry model outputs on the total carbon stock in area under forest cover (in million tonnes carbon and in billion tonnes CO₂-e)

Year	Total carbon stock in forest land (MtC)			Total carbon stock in forest land in billion tonnes CO ₂ -e			Percentage of difference between FSI technical report and Forestry model	Percentage of difference between National GHG inventory and Forestry model
	National GHG inventory total carbon stock in forest land in million tonnes carbon	FSI technical report forest cover carbon stock in million tonnes carbon	Forestry model forest cover carbon stock in million tonnes carbon	National GHG inventory total carbon stock in forest land in billion tonnes CO ₂ -e	FSI technical report forest cover carbon stock in billion tonnes CO ₂ -e	Forestry model forest cover carbon stock in billion tonnes CO ₂ -e		
2011	7004.36	6941.00	7094.28	25.68	25.45	26.01	2.41	1.28
2012	7024.18		7061.37	25.76		25.89		0.53
2013	7044.00	7044.00	7081.81	25.83	25.83	25.97	0.54	0.54
2014	7063.00		7101.57	25.90		26.04		0.55
2015	7082.00	7082.00	7082.12	25.97	25.97	25.97	0.00	0.00
2016	7103.00		7117.92	26.04		26.10		0.21

5. Results and discussion

The main results for each scenario explored to achieve the NDC targets are outlined in this section and Table 4. As seen in Table 4, the 2030 NDC targets with respect to the total CO₂-e sink (32 billion tonnes and 32.5 billion tonnes) are achieved in each scenario, but each comes with a set of challenges and barriers.



Table 4: Effort required or result achieved from the most (green) to the least (red) for each intervention/variable across the scenarios

Scenario	Increase or decrease in area in addition to the Reference scenario (Hectares)					Total CO ₂ -e sink (Billion tonnes)		Annual carbon capture (Million tonnes CO ₂ -e)		Percentage of forest and tree cover	
	Afforestation		Deforestation	Restoration	Degradation	2030	2070	2030	2070	2030	2070
	Forest cover	Tree cover									
Reference	657770	56026	510610	617705	321680	31.1	35.1	302	329	25.50	28.80
NDC-1 Aff	+ 263108	+ 33615	0	0	0	32.0	40.4	345	401	26.3	33.3
NDC-1 Def	0	0	- 306366	0	0	32.0	40.6	345	351	26.3	33.3
NDC-1 Aff+Res	+131554	+ 28013	0	+ 555935	0	32.0	38.0	331	398	26.3	31.2
NDC-1 Def+Deg+Res	0	0	- 178714	+ 308853	- 160840	32.0	38.4	308	367	26.2	31.4
NDC-1 Aff+Def+Deg+Res	+ 98666	+ 28013	-51061	+ 308853	- 160840	32.0	38.3	326	390	26.2	31.4
NDC-2 Aff	+ 427551	+ 56026	0	0	0	32.5	43.7	373	446	26.8	35.9
NDC-2 Def	0	0	- 459549	0	0	32.5	43.4	306	362	26.7	35.6
NDC-2 Aff+Res	+ 263108	+ 47622	0	+ 617705	0	32.5	40.7	354	439	26.7	33.4
NDC-2 Def+Deg+Res	0	0	- 280836	+ 494164	- 257344	32.5	40.2	313	389	26.7	33.0
NDC-2 Aff+Def+Deg+Res	+ 197331	+ 33615	- 76592	+ 432394	- 225176	32.5	40.7	344	426	26.7	33.3

Note: BAU – Business as usual, Aff – Afforestation, Def – Deforestation, Res – Restoration, and Deg – Degradation; the + sign indicates an increase in the area under afforestation and restoration; and the – sign indicates a reduction in area under deforestation and degradation.

5.1. Aggressive afforestation scenario: NDC-1 Aff and NDC-2 Aff

In this scenario, maximum annual carbon capture and maximum increase in the percentage of forest and tree cover are seen compared to all other scenarios. The high annual carbon capture is because of the aggressive rate of afforestation as new young forests with high carbon capture ability are added compared to the BAU scenario. The National Forest Policy 1988 aims at maintaining one third of the geographical area of the country under forest and tree cover (Press Information Bureau, 1988). Under this scenario, the 33% forest and tree cover target is met by 2070 in the NDC-1 scenario and by 2057 in the NDC-2 scenario. A total of 0.3 million hectares and 0.5 million hectares of additional area each year is required to be planted for realising the NDC-1 and NDC-2 targets, respectively. However, the forest and tree cover expansion in these two scenarios is contingent on land availability. This has implications for land as there is likely to be competition for land for the agriculture and renewable energy (solar and wind farms) sectors.

5.2. Reduced deforestation scenario: NDC-1 Def and NDC-2 Def

The total CO₂-e sink achieved in 2070 is similar to the afforestation scenario (40.6 and 43.4 billion tonnes of CO₂-e). However, the annual carbon capture in 2070 is the lowest in both NDC-1 (351 million tonnes CO₂-e) and NDC-2 (362 million tonnes CO₂-e), compared to all other scenarios. This low annual carbon capture can be attributed to the absence of additional efforts for forest and tree cover expansion (no afforestation). This leads to a lesser area under young forests compared to the other scenarios and thus a lower carbon capture as young forests have higher carbon capture ability compared to old-growth forests.

Under the Forest Conservation Act of 1980, a large reduction in deforestation was seen between 1980 and 2000 (Ministry of Environment, Forest and Climate Change, 2015). Under this Act, the indiscriminate diversion of forest land for non-forest purposes and land-use change in forests are strictly controlled and regulated. However, demand for land is bound to increase in India because of the various developmental goals of the nation. This demand can increase the need to divert forest land for non-forest purposes. Although the NDC targets are achievable, a drastic reduction in deforestation activities, such as in this scenario, may not be realistically achievable.

5.3. Afforestation and restoration scenario: NDC-1 Aff + Res and NDC-2 Aff + Res

Both the National Afforestation Programme and the Green India Mission aim at not only creating new forest areas but also restoring scrubland and improving the quality of existing forests (Ministry of Environment, Forest and Climate Change, 2015). This scenario was developed keeping these policies in mind along with the fact that aggressive afforestation alone (e.g., NDC-1 Aff and NDC-2 Aff scenarios) would be constrained by land availability.

In this scenario, to achieve the NDC targets, efforts in restoration activities need to be doubled compared to other scenarios considering restoration. Although the total CO₂-e sink created is lower in 2070 compared to the other two scenarios, the total annual carbon capture goes up to 398 million tonnes of CO₂-e compared to 351 million tonnes in the reduced deforestation scenario because of new areas brought under forests/restored areas. In the NDC-1 scenario, the percentage of forest and tree cover reaches 33% only by 2087, whereas in NDC-2, this is achieved by 2068.

It is important to note that the doubling of restoration activities is dependent on total scrubland availability and the viability of open forests being restored to either MDF or VDF classes. Many factors such as the physiography of the area and the local climatic conditions can influence the viability of restoration activities (Chazdon & Guariguata, 2016). Moreover, both scrubland and open forests are important ecosystems that support unique biodiversity (Nerlekar & Veldman, 2020). Therefore, the ecological importance of these ecosystems is an important consideration that would drive the decision to convert scrubland and open forests to denser forests.

5.4. Reduced deforestation and degradation and increased restoration scenario: NDC-1 Def + Deg + Res and NDC-2 Def + Deg + Res

This scenario was developed in line with the National REDD+ strategy (reducing emissions from deforestation and degradation along with enhancing the role of conservation and sustainable management of forests). In this scenario, although the target is achievable with a moderate reduction in deforestation activities, the total annual carbon capture is low. The reason for this is similar to the aggressive reduction in deforestation activities in the NDC-1 Def and NDC-2 Def scenarios where no additional afforestation is taken up, leading to lesser areas under young forests. The percentage of forest and tree cover is also low, and the 33% forest and tree cover target is achieved only by 2087 for the NDC-1 scenario. Despite the low carbon capture, this scenario demonstrates the potential of increased efforts in conservation and restoration being able to bring down deforestation by almost half, both in NDC-1 and NDC-2 scenarios.

5.5. Afforestation and restoration and reduced deforestation and degradation scenario: NDC-1 Aff + Def + Deg + Res and NDC-2 Aff + Def + Deg + Res

This scenario looked at the minimum effort required considering all interventions to achieve the NDC targets. Under both NDC-1 and NDC-2 scenarios, moderate levels of annual carbon capture and total CO₂-e sink are realised by 2070. The percentage of forest and tree cover reaches 33% by 2070 in NDC-2, while the NDC-1 target is met by 2081.

Since this scenario involves a combination of all the interventions, with the least effort required for each intervention, it could be the most sustainable scenario for long-term forest land management, keeping in mind the other developmental goals of the country. An important aspect to consider here is the trade-off between forest land diverted for non-forest purposes via deforestation and non-forest land being brought under forest through afforestation. To understand this further, the effect on land availability because of reduced deforestation and increased afforestation needs to be assessed, which will be explored in the next phase of work.

6. Forest policies in India

The Government of India has several policies and programmes that promote the conservation and restoration of forests, aiding the already existing policies for afforestation and reduction in deforestation. The Compensatory Afforestation Fund Act, 2016, aims at compensating for the loss of forests because of developmental activities by restoring degraded forest land, improving the quality of existing forests, and creating new forest land (Ministry of Environment, Forest and Climate Change, 2015). Although the overall carbon capture can be compensated for, the loss of stored carbon would take a long time to be restored. It is therefore important to assess the biodiversity loss and how that can be compensated for.

As mentioned previously, the National REDD+ strategy, 2018, was considered while designing the scenarios. This strategy aims at reducing emissions from deforestation and forest degradation in the country and promoting the conservation and sustainable management of forest land (Ministry of Environment, Forest and Climate Change, 2015). Relying solely on the reduction in planned harvest and/or forest land-use change could have various other implications such as loss of livelihood for people dependant on these services like timber harvest and the unavailability of land for many developmental projects.

Apart from the expansion of forests, the Government of India also has many policies in place with respect to tree cover expansion, such as the Green Highway Policy, Urban Green Policy, Nagar Van Yojana, and Agroforestry Policy (Ministry of Environment, Forest and Climate Change, 2015). The expansion of tree cover outside forest areas will increase the carbon sequestration potential of the country and have various other benefits such as urban cooling, enhancing biodiversity, and economic benefits via agroforestry systems.

It is important to note that the policies and programmes implemented in the country work synergistically to promote forest expansion as seen in Scenario 5 (NDC-1 and NDC-2 Aff + Def + Deg + Res), which appears to be the most viable long-term strategy. Hence, it is imperative to consider how land-use changes and demand for forest products and services affect each intervention. It is also important to understand the collective effect of these interventions in improving and expanding forest cover on the other interacting sectors of the country such as agriculture and renewable energy. Yet another key factor that would determine the implementation of a scenario is land availability and the costs associated with such plantation drives.

7. Way forward

The current model has been developed to gain a robust understanding of the forest sector. We plan to integrate the forestry module into SAFARI 2.0 (Ashok et al., 2021), which will help unravel and understand the various trade-offs in the expansion of forest and tree cover as well as the costs associated with it. Future directions for this work (and the caveats with the current analysis) are outlined below:

1. India has low per capita availability of land, which implies pronounced pressure on natural resources, such as land, with the increasing population (Ministry of Environment, Forest and Climate Change, 2015). The impacts on forestry arising from land availability problems and resource competition with other sectors, largely the agriculture and renewable energy sectors, will be examined in the next phase.
2. Aspects such as forest types, species composition of forests, and the resultant variation in productivity will be incorporated in the next phase of the model, contingent on data availability.
3. The reasons for degradation, such as fire and selective logging, are not explicitly considered in the model. The lack of such a distinction restricts the understanding of how natural regeneration of degraded land contributes towards the restoration of forests versus active restoration activities such as plantation drives. In the next phase, we will incorporate this aspect to the extent possible, contingent on data availability, to add further nuance to the analysis in terms of policy interventions.
4. The Central Empowered Committee (CEC), instituted by the Supreme Court of India, recently revised the economic value of goods and services provided by the forests (Ministry of Environment, Forest and Climate Change, 2021a). These include timber, ecotourism, carbon sequestration, ecological services, fodder, fuelwood, bioprospecting, and flagship species, which are incorporated into estimating the economic cost of land-use change. In the upcoming phases of the model development, efforts to include such cost analyses of each intervention under various strategies will be made.

8. References

- Ashok, K., Kumar, P., & Natrajan, R. (2021). *Sustainable Alternative Futures for India (Phase 3 & 4)*.
https://www.cstep.in/drupal/sites/default/files/2021-07/CSTEP_SAFARI_Final_Report_July2021.pdf
- Chazdon, R. L., & Guariguata, M. R. (2016). Natural regeneration as a tool for large-scale forest restoration in the tropics: Prospects and challenges. *Biotropica*, 48(6), 716–730.
<https://doi.org/10.1111/btp.12381>
- Forest Survey of India. (2013). *India State of Forest Report*.
- Forest Survey of India. (2019). *India's Nationally Determined Contribution of creating an additional carbon sink of 2.5 to 3 billion tonnes of CO₂-eq through additional forest and tree cover: Possibilities, scale and cost for formulating strategy* (Volume 1 No. 3; FSI Technical Information Series). <https://fsi.nic.in/uploads/documents/technical-information-series-vol1-no3-16-06-2019.pdf>
- Forest Survey of India. (2021). *Indian State Forest Report*. <https://fsi.nic.in/forest-report-2021>
- Houghton, R. A., & Hackler, J. L. (2001). Emissions of carbon from forestry and land-use change in tropical Asia. *Global Change Biology*, 5(4), 481–492. <https://doi.org/10.1046/j.1365-2486.1999.00244.x>
- Levin, K., Rich, D., Ross, K., Fransen, T., & Elliott, C. (2020). *Designing and Communicating Net-Zero Targets*. Washington, DC: World Resources Institute. www.wri.org/design-net-zero.
- Malhi, Y. (2012). The productivity, metabolism and carbon cycle of tropical forest vegetation: Carbon cycle of tropical forests. *Journal of Ecology*, 100(1), 65–75.
<https://doi.org/10.1111/j.1365-2745.2011.01916.x>
- Ministry of Environment, Forest and Climate Change. (2015). *State of Environment Report*.
<https://moef.gov.in/wp-content/uploads/2019/09/Final-SoER-2015-India-.pdf>
- Ministry of Environment, Forest and Climate Change. (2021a). *Revision of the rates of Net Present Value (NPV) of forest land diverted for non-forest purpose*.

https://forestsclearance.nic.in/writereaddata/meeting_notice/22_Jan_2021_1945255701DraftCoSNoteonNPVrevision.pdf

Ministry of Environment, Forest and Climate Change. (2021b). *Third Biennial Update Report to the United Nations Framework Convention on Climate Change*.
https://unfccc.int/sites/default/files/resource/INDIA_%20BUR-3_20.02.2021_High.pdf

Ministry of Environment, Forest and Climate Change. (2022). *India's Long-Term Low-Carbon Development Strategy*. https://unfccc.int/sites/default/files/resource/India_LTLEDS.pdf

Nerlekar, A. N., & Veldman, J. W. (2020). High plant diversity and slow assembly of old-growth grasslands. *Proceedings of the National Academy of Sciences*, 117(31), 18550–18556.
<https://doi.org/10.1073/pnas.1922266117>

Press Information Bureau. (1988). *National Forest Policy 1988*.
<https://asbb.gov.in/Downloads/National%20Forest%20Policy.pdf>

Press Information Bureau. (2022). *India's updated Nationally Determined Contribution (NDC)*. PIB.
<https://pib.gov.in/PressReleaseIframePage.aspx?PRID=1847812>

United Nations Environment Programme. (2022). *Emissions Gap Report 2022: The Closing Window—Climate crisis calls for rapid transformation of societies*.
<https://www.unep.org/emissions-gap-report-2022>





CENTER FOR STUDY OF SCIENCE, TECHNOLOGY & POLICY

Bengaluru

#18, 10th Cross, Mayura Street, Papanna Layout,
Nagashettyhalli, RMV II Stage, Bengaluru 560094
Karnataka (India)

Noida

1st Floor, Tower-A, Smartworks Corporate Park, Sector 125,
Noida 201303, Uttar Pradesh (India)



www.cstep.in



+91-8066902500



cpe@cstep.in



[@cstep_India](https://twitter.com/cstep_India)